

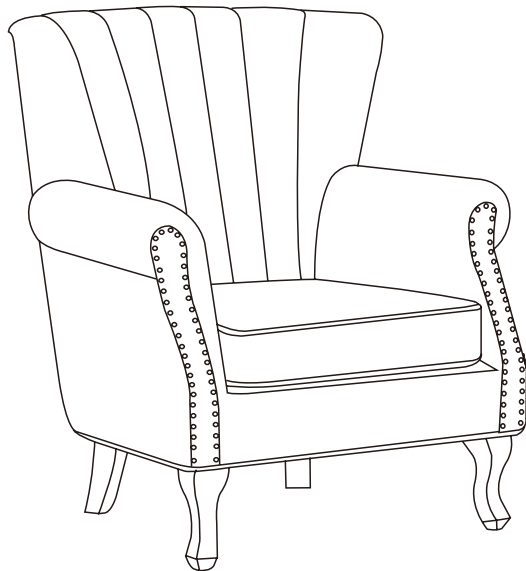

ASSEMBLY INSTRUCTION

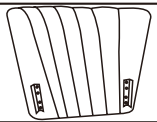

Accent Chair

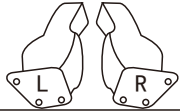
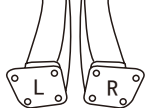

Component List

LABEL	DESCRIPTION	QTY
A	 Chair Back	1
B	 Chair Seat	1
C	 Front Legs	2
D	 Rear Legs	2

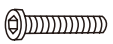
Hardware List

LABEL	DESCRIPTION	QTY
H1	 Bolts M6*20MM	14
H5	 Allen Key M5	1
H6	 Felt Pad	4

Assembly Steps

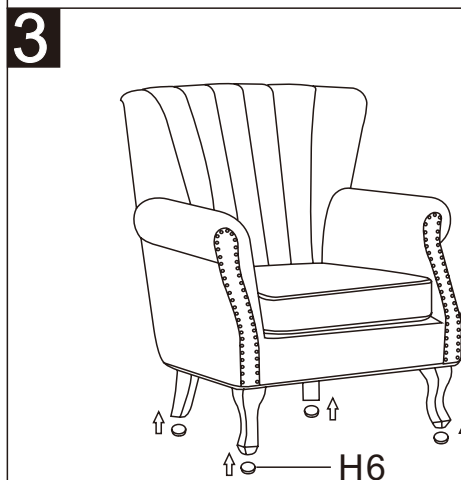
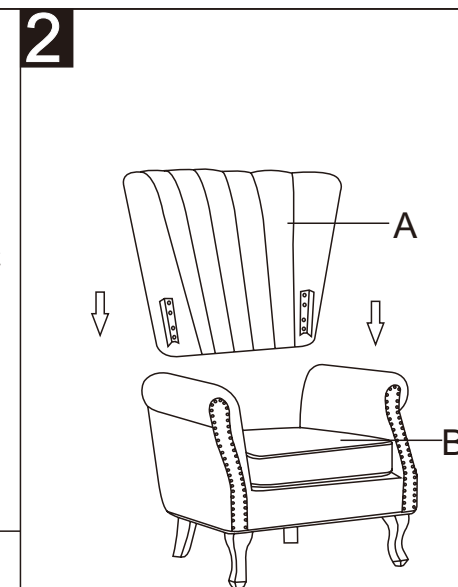
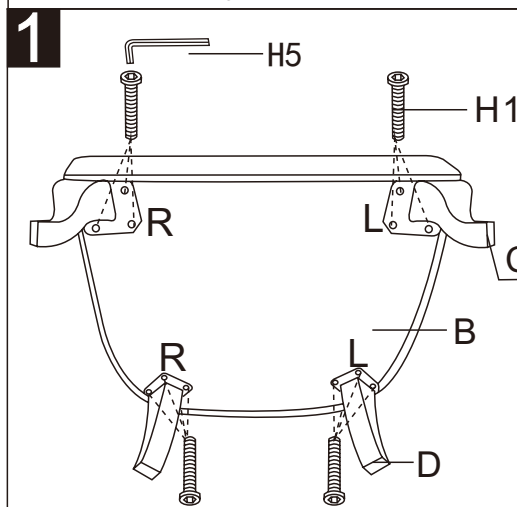

1. Align the pre-installed v-brackets on the Chair Back(A) with the corresponding brackets on the back edge of Chair Seat(B), the v-brackets will slide down into the receiving brackets once both aligned.
2. Press firmly down on Chair Back(A) to secure the Chair Back(A) to Chair Seat(B).

W przypadku reklamacji wymagany jest nr seryjny, który znajduje się na produkcie (np. pod siedziskiem) lub na dołączonej instrukcji.

Prosimy o zachowanie numeru seryjnego.

In the event of a complaint, the serial number is required, which can be found on the product (eg. under the seat) or on the attached manual instruction.

Please keep the serial number.

*Wyprodukowano dla/Made for
MEBEL ELITE SP. Z O.O.*

*Bako czycka 7
37-700 Przemyśl*

*Wyprodukowano w Chinach/Made in China
Batch code: PLHME-02*