

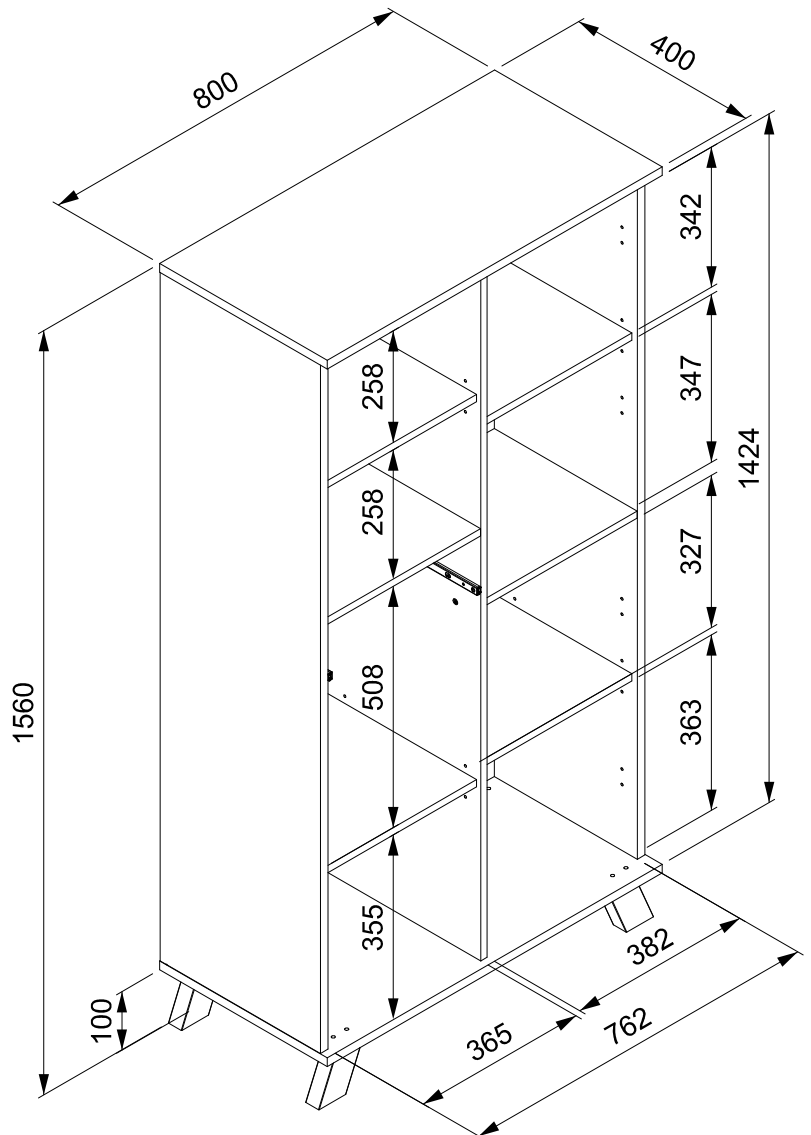

MDN53A/137

finori GmbH
Straßacker 2
D - 96253 Untersiemau

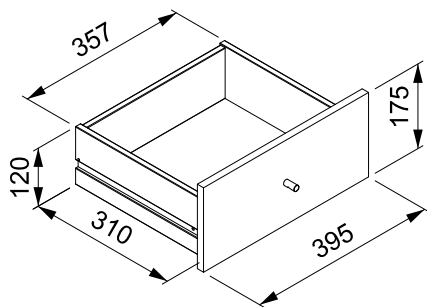

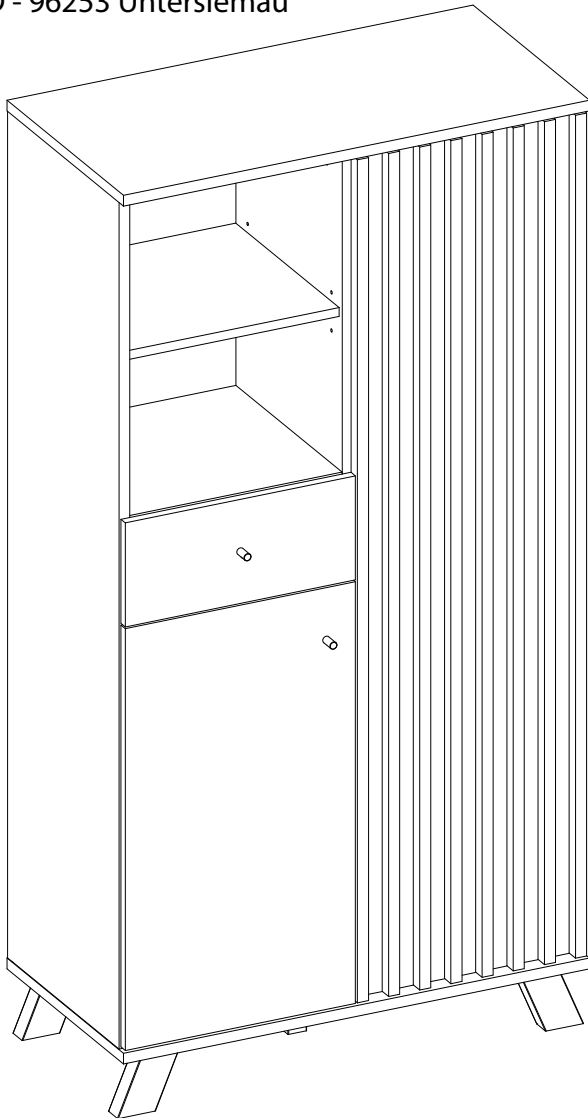

- Ⓛ Deur Befolgen Sie stets die Anleitung des Herstellers!
- Ⓛ Deur Please generally follow the manufacturer's instructions!
- Ⓛ Deur Suivez toujours les instructions du fabricant!
- Ⓛ Deur Volg steeds de handleiding van de producent!
- Ⓛ Deur Siga siempre las instrucciones del fabricante!
- Ⓛ Deur Stale przestrzegaj instrukcji producenta!

- Ⓛ Deur Всегда следуйте инструкции производителя!
- Ⓛ Deur Seguire sempre le istruzioni del produttore!
- Ⓛ Deur Mindig tartsa be a gyártó utasításait!
- Ⓛ Deur Siga sempre as instruções do fabricante!
- Ⓛ Deur Vždy dodržujte pokyny výrobce!



- Ⓛ Deur Verwenden Sie zur Reinigung nur ein feuchtes Tuch!
- Ⓛ Deur Please only clean with a damp cloth!
- Ⓛ Deur N'utilisez qu'un chiffon humide pour le nettoyage!
- Ⓛ Deur Gebruik voor de reiniging enkel een vochtige doek!
- Ⓛ Deur Para limpiar utilice sólo un paño húmedo!
- Ⓛ Deur Do czyszczenia używaj wilgotnej szmatki!

- Ⓛ Deur Для очистки используйте только влажную ткань!
- Ⓛ Deur Per la pulizia, utilizzare solo un panno umido!
- Ⓛ Deur A tisztításhoz elegendő egy nedves kendő használat!
- Ⓛ Deur Para a limpeza use apenas um pano húmido!
- Ⓛ Deur Pro čištění používejte pouze vlhký hadřík!



- Ⓛ Deur Bauen Sie das Produkt auf einer Unterlage auf!
- Ⓛ Deur Please mount the product on a bottom support!
- Ⓛ Deur Montez le produit sur une base!
- Ⓛ Deur Monteer het product op een basis!
- Ⓛ Deur Monte el producto sobre una base!
- Ⓛ Deur Rozkładaj produkt na podkładce!

- Ⓛ Deur Собирайте изделие на подстилке!
- Ⓛ Deur Montare il prodotto su un supporto!
- Ⓛ Deur Az összeszereléskor helyezzen a termék alá megfelelő alátétet!
- Ⓛ Deur Monte o produto numa superfície plana!
- Ⓛ Deur Výrobek smontujte na pevném podkladu!

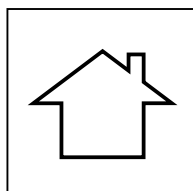

- Ⓛ Deur Verwenden Sie das Produkt nur in Innenräumen!
- Ⓛ Deur Please exclusively use the product indoors!
- Ⓛ Deur N'utilisez le produit qu'à l'intérieur!
- Ⓛ Deur Gebruik het product enkel binnenshuis!
- Ⓛ Deur Utilice el producto sólo en interiores!
- Ⓛ Deur Używaj produkt tylko w pomieszczeniach wewnętrznych!

- Ⓛ Deur Используйте изделие только во внутренних помещениях!
- Ⓛ Deur Utilizzare il prodotto solo in ambienti interni!
- Ⓛ Deur A termék csak bel terekben használható!
- Ⓛ Deur Use o produto apenas no interior!
- Ⓛ Deur Používejte výrobek pouze uvnitř!



- Ⓛ Deur Legen Sie die Beschläge zusammen und prüfen Sie die Vollständigkeit!
- Ⓛ Deur Please join the fittings and verify their completeness!
- Ⓛ Deur Pliez les raccords ensemble et vérifiez qu'ils sont complets!
- Ⓛ Deur Leg de onderdelen samen en controleer de volledigheid!
- Ⓛ Deur Junte los accesorios y compruebe que están todos!
- Ⓛ Deur Rozlož poszczególne części i sprawdź kompletność!

- Ⓛ Deur Положите фурнитуру в одно место и проверьте комплектность!
- Ⓛ Deur Mettere insieme le guarnizioni e verificarne la completezza!
- Ⓛ Deur Állítsa össze a sarokvasakat, és ellenőrizze, hogy épek-e!
- Ⓛ Deur Coloque os encaixes juntos e verifique se estão completos!
- Ⓛ Deur Složte armatury a zkontrolujte úplnost!



- Ⓛ Deur Bei fehlenden Teilen kontaktieren Sie den Hersteller!
- Ⓛ Deur If parts are missing, please turn to the manufacturer!
- Ⓛ Deur En cas de pièces manquantes, veuillez contacter le fabricant!
- Ⓛ Deur Contacteer de fabrikant als er onderdelen ontbreken!
- Ⓛ Deur En el caso de que falten piezas, póngase en contacto con el fabricante!
- Ⓛ Deur W razie braku części skontaktuj się z producentem!

- Ⓛ Deur При отсутствии каких-либо частей обратитесь к производителю!
- Ⓛ Deur In caso di pezzi mancanti, contattare il produttore!
- Ⓛ Deur Ha hiányozna valamelyik elem, lépjen kapcsolatba a gyártóval!
- Ⓛ Deur Em caso de peças em falta, entre em contato com o fabricante!
- Ⓛ Deur Pro chybějící díly kontaktujte výrobce!



- Ⓛ Deur Ziehen Sie die Schrauben nach einiger Zeit des Gebrauchs erneut fest!
- Ⓛ Deur Please re-tighten the screws after having used the product for a while!
- Ⓛ Deur Resserrer les vis après un certain temps d'utilisation!
- Ⓛ Deur Draai de schroeven na een zekere gebruikstijd opnieuw vast!
- Ⓛ Deur Asegure de nuevo los tornillos tras usarlo durante un tiempo!
- Ⓛ Deur Po pewnym czasie użytkowania ponownie dokręć śruby!

- Ⓛ Deur Спустя некоторое время использования подкрутите гайки!
- Ⓛ Deur Stringere nuovamente le viti dopo un certo periodo di utilizzo!
- Ⓛ Deur A használat során némi idő elteltével húzza meg újra a csavarokat!
- Ⓛ Deur Reaperte os parafusos após algum tempo de uso!
- Ⓛ Deur Po určité době používání šrouby znovu utáhněte!



MDN53A/137

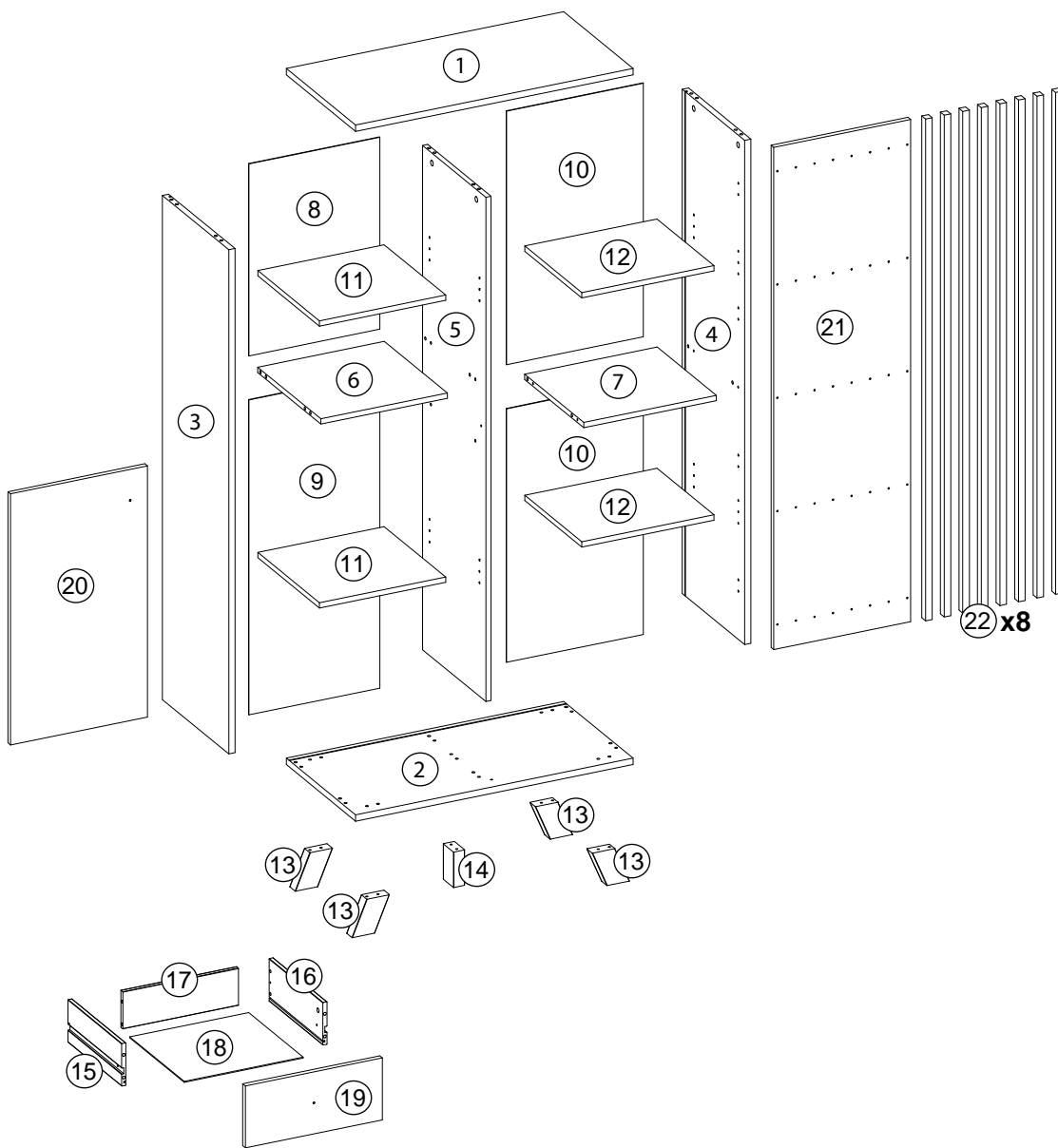
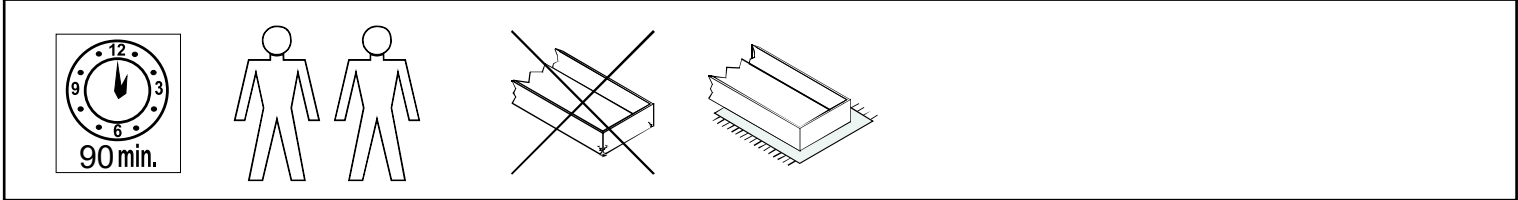

Dimensions / Abmessung in mm/		
①	1 x	800 x 400 x 18
②	1 x	800 x 400 x 18
③	1 x	1424 x 383 x 18
④	1 x	1424 x 360 x 18
⑤	1 x	1424 x 365 x 15
⑥	1 x	365 x 364 x 15
⑦	1 x	382 x 341 x 15
⑧	1 x	542 x 377 x 2,5
⑨	1 x	889 x 377 x 2,5
⑩	2 x	716 x 394 x 2,5
⑪	2 x	364 x 355 x 15
⑫	2 x	381 x 329 x 15
⑬	4 x	100 x 60 x 32
⑭	1 x	100 x 60 x 32
⑮	1 x	310 x 120 x 12
⑯	1 x	310 x 120 x 12
⑰	1 x	333 x 105 x 12
⑱	1 x	343 x 314 x 2,5
⑲	1 x	395 x 175 x 15
⑳	1 x	709 x 395 x 15
㉑	1 x	1418 x 395 x 15
㉒	8 x	1417 x 19 x 22

BOX 1	3, 4, 5, 21, 22
BOX 2	1, 2, 6, 7, 8, 9, 10, 11, 12, 13, 14, 15, 16, 17, 18, 19, 20



BOX 1	
BOX 2	✓

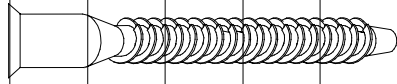

f3 x 20

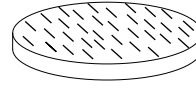

p33 x 5

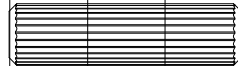

b2 x 26



c2 x 12

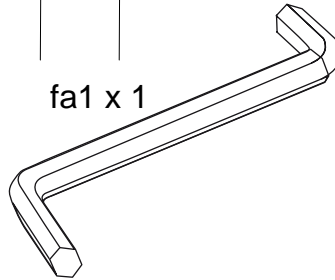

fa1 x 1



a3 x 2

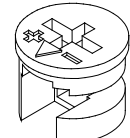

a1 x 10



o1 x 8



d11 x 12

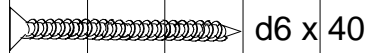

d6 x 40

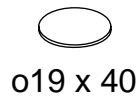

o19 x 40

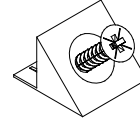

m1 x 8

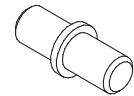

n1 x 16



da20 x 10

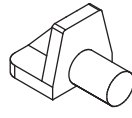

r4 x 1



o4 x 12

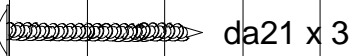

da21 x 3

i5 x 2



e4 x 4

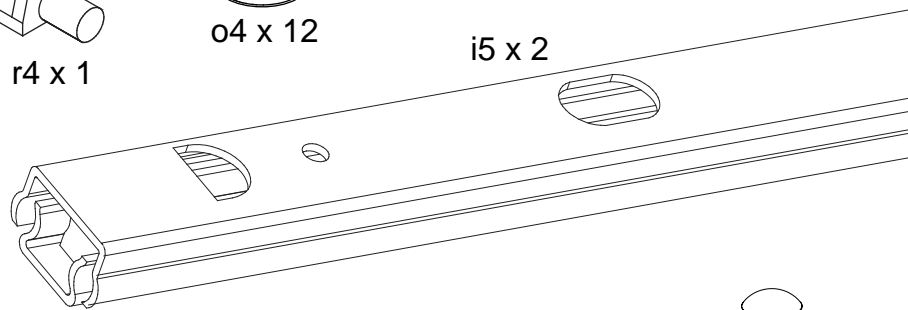

h6 x 2



r5 x 1

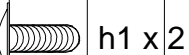

h1 x 2

k6 x 6

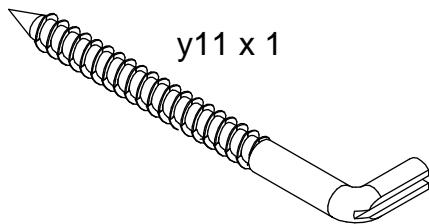
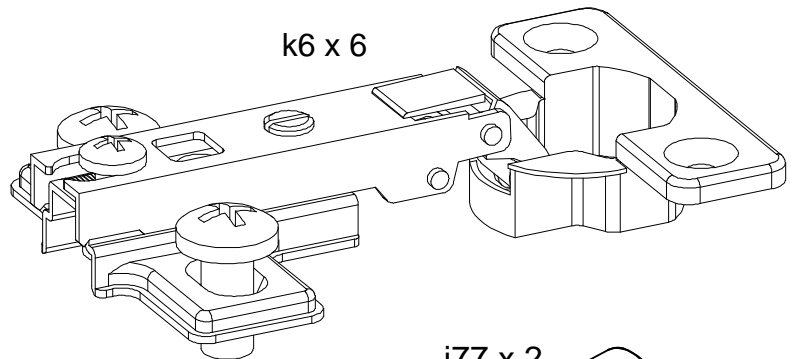

y11 x 1

j77 x 2

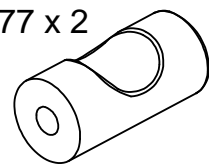

A

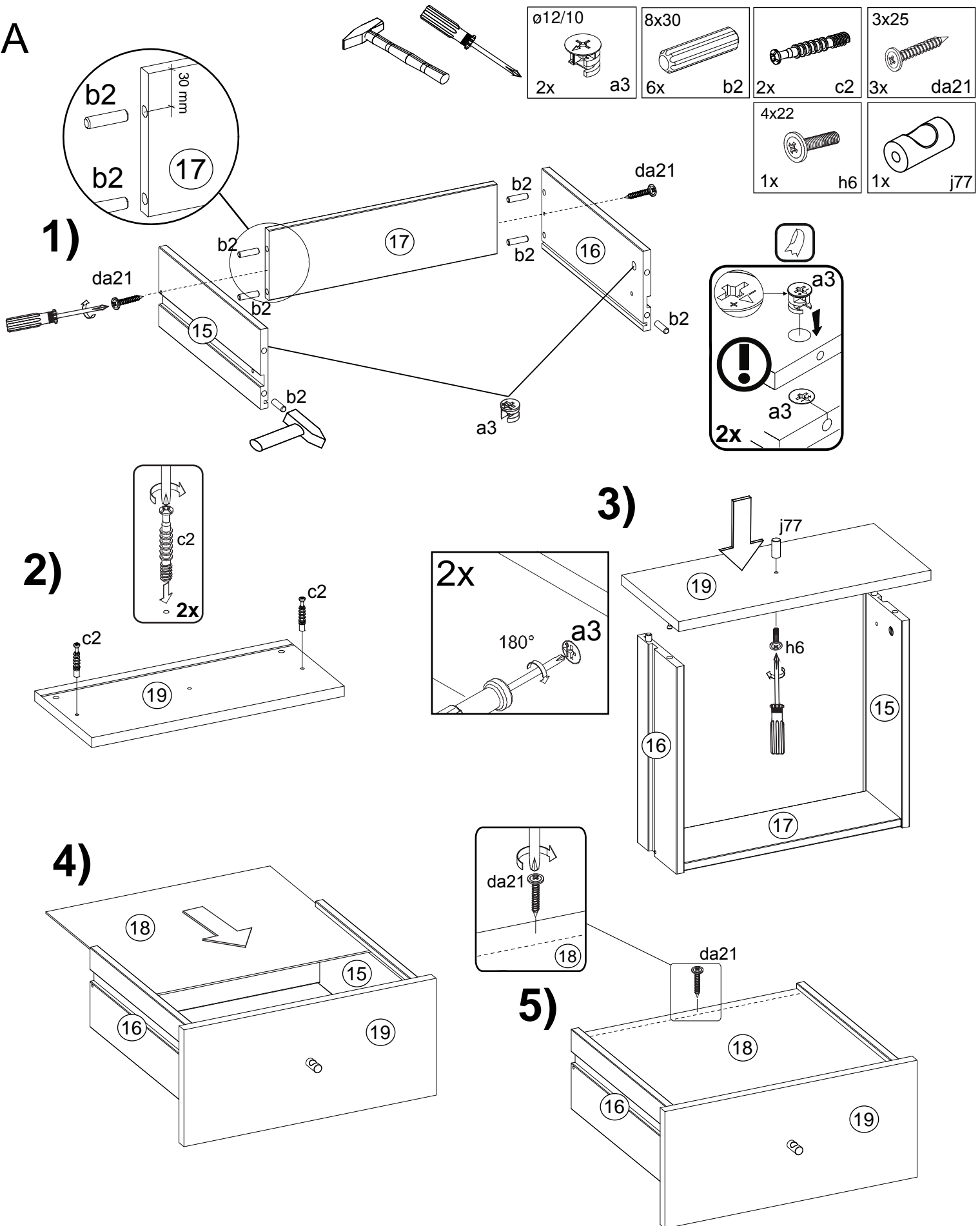

B

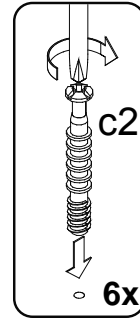
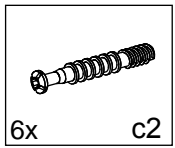
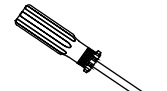
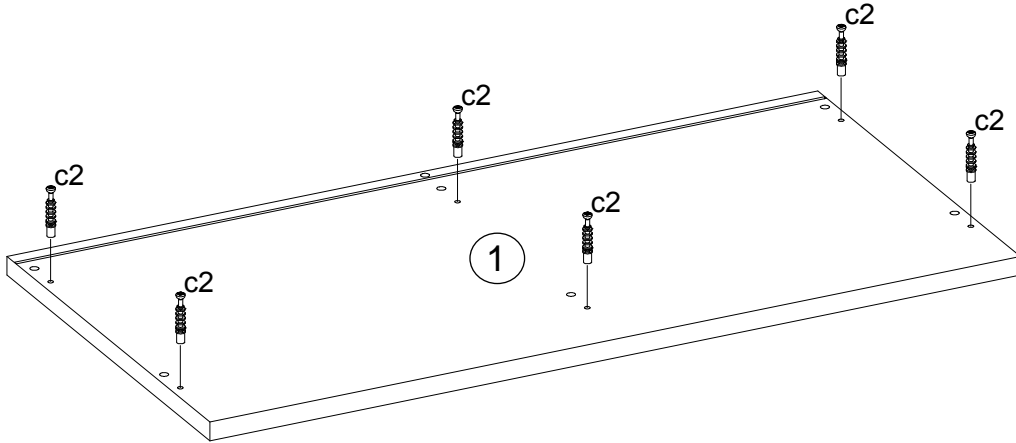

C

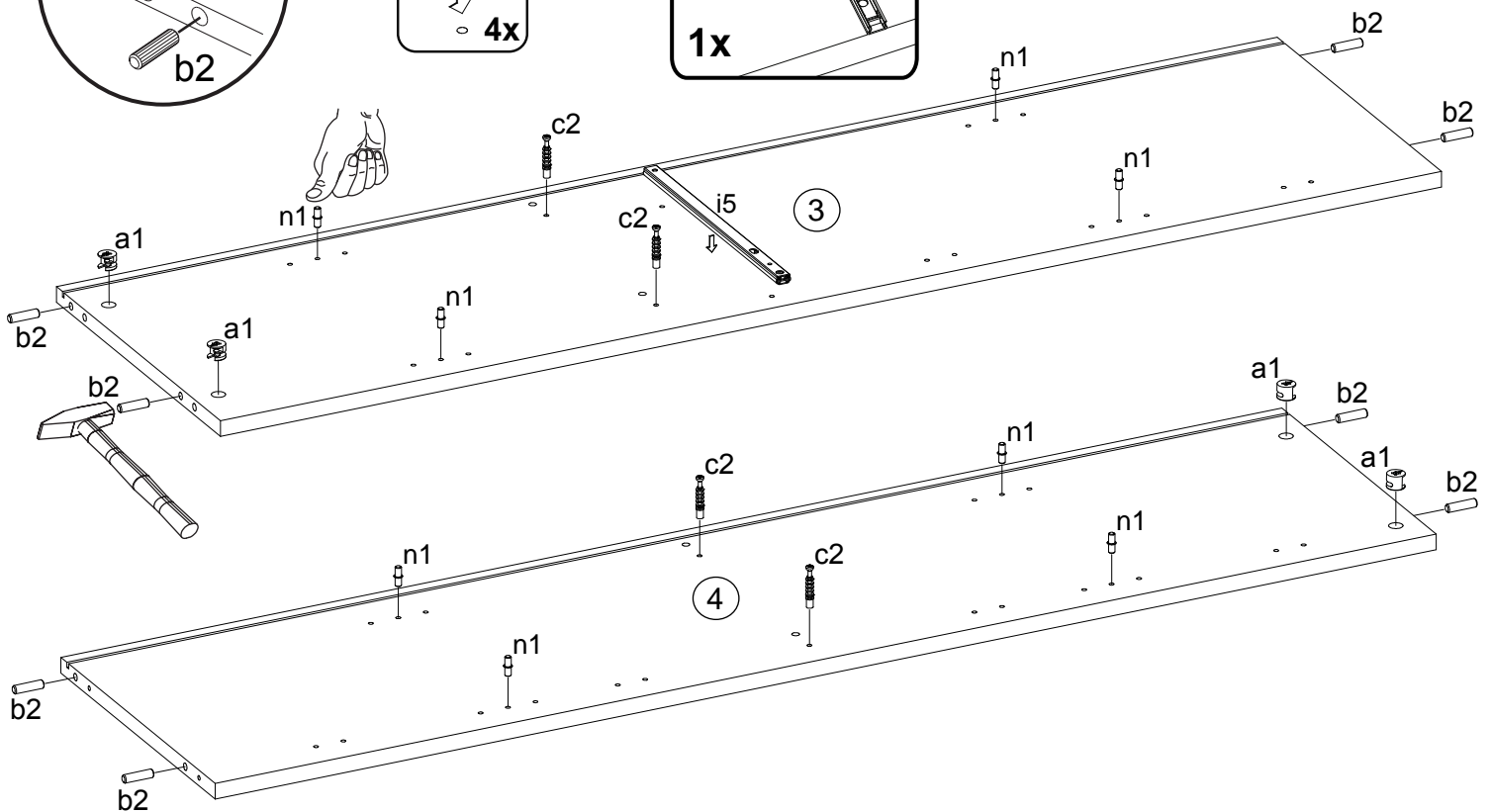
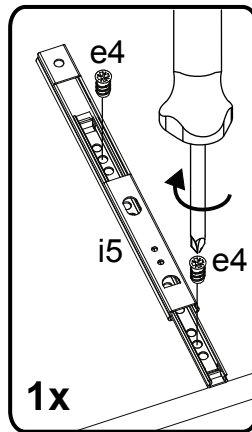
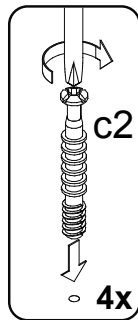
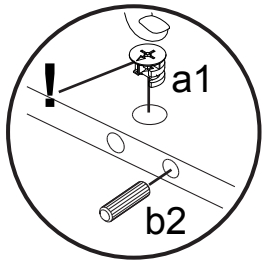
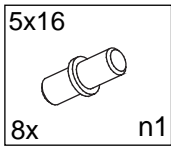
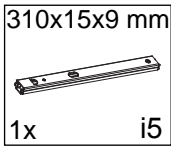
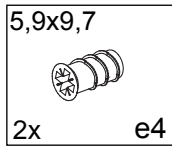
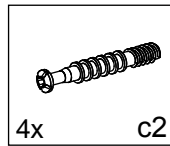
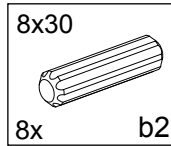
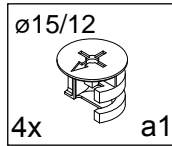
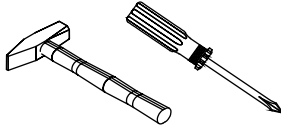

D

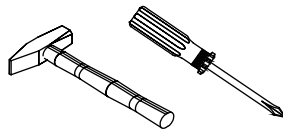

$\varnothing 15/12$ 2x a1	8x30 4x b2	5,9x9,7 2x e4	310x15x9 mm 1x i5	5x16 8x n1
----------------------------------	-------------------	----------------------	--------------------------	-------------------

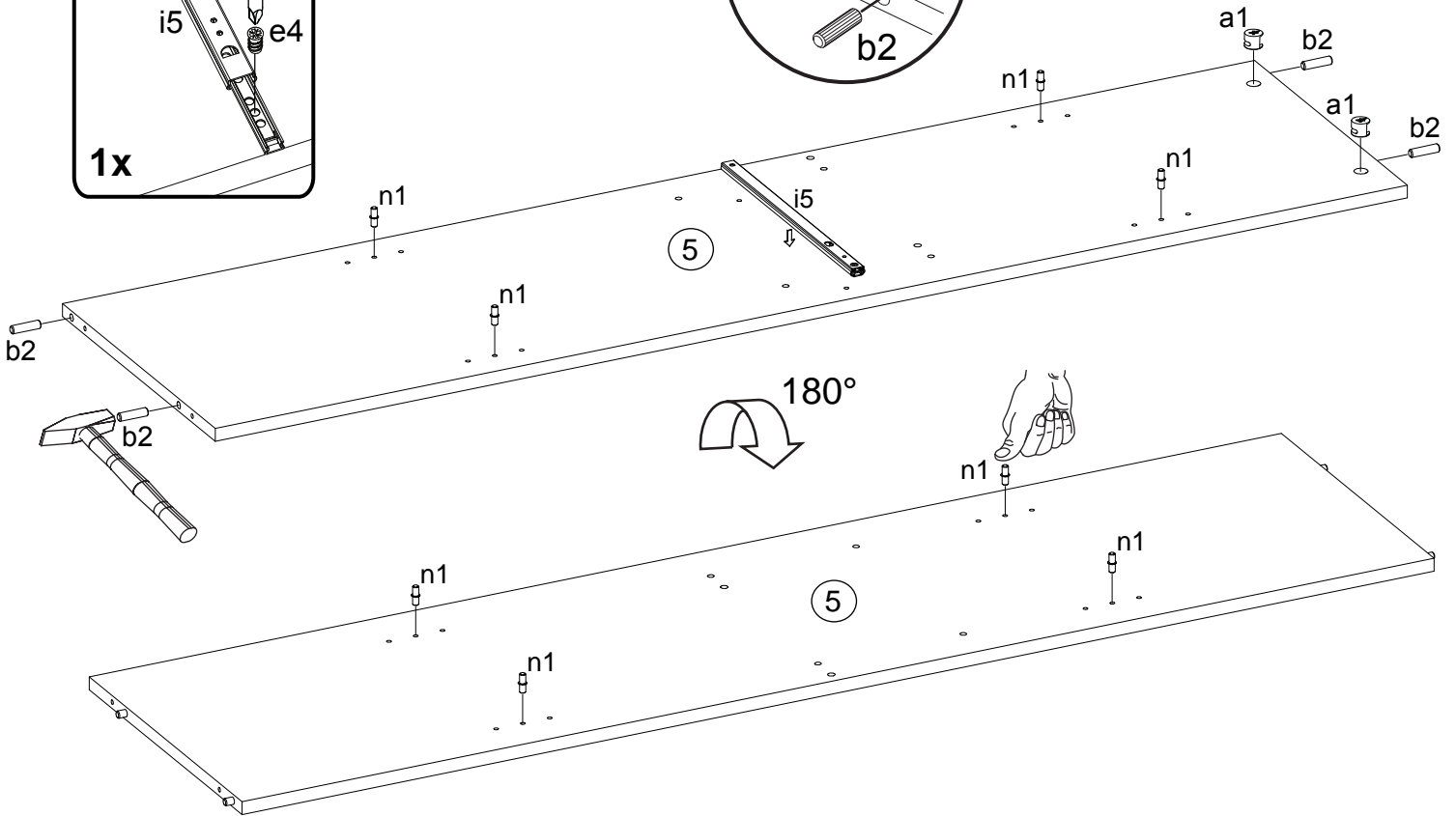
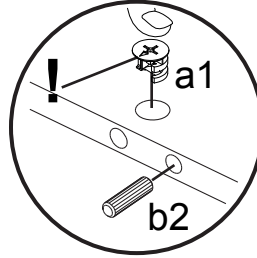
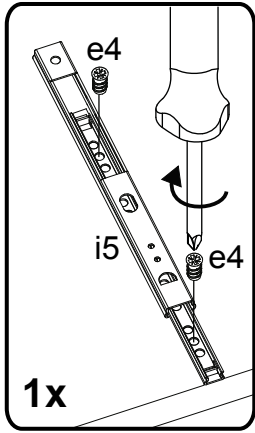

E

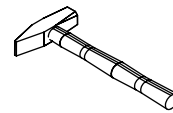

$\varnothing 15/12$ 4x a1	8x30 8x b2
----------------------------------	-------------------

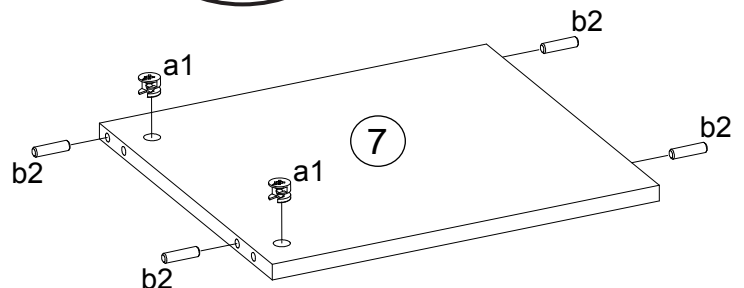
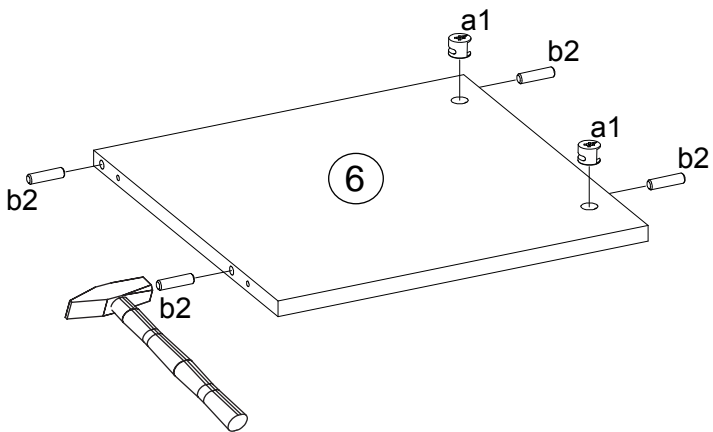
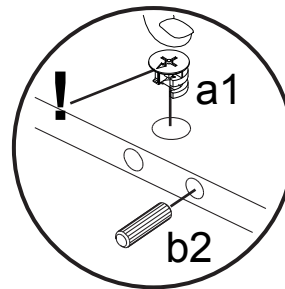



MDN53A/137

F

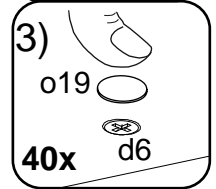
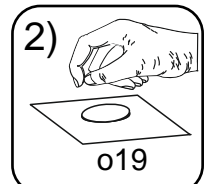
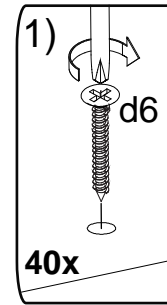
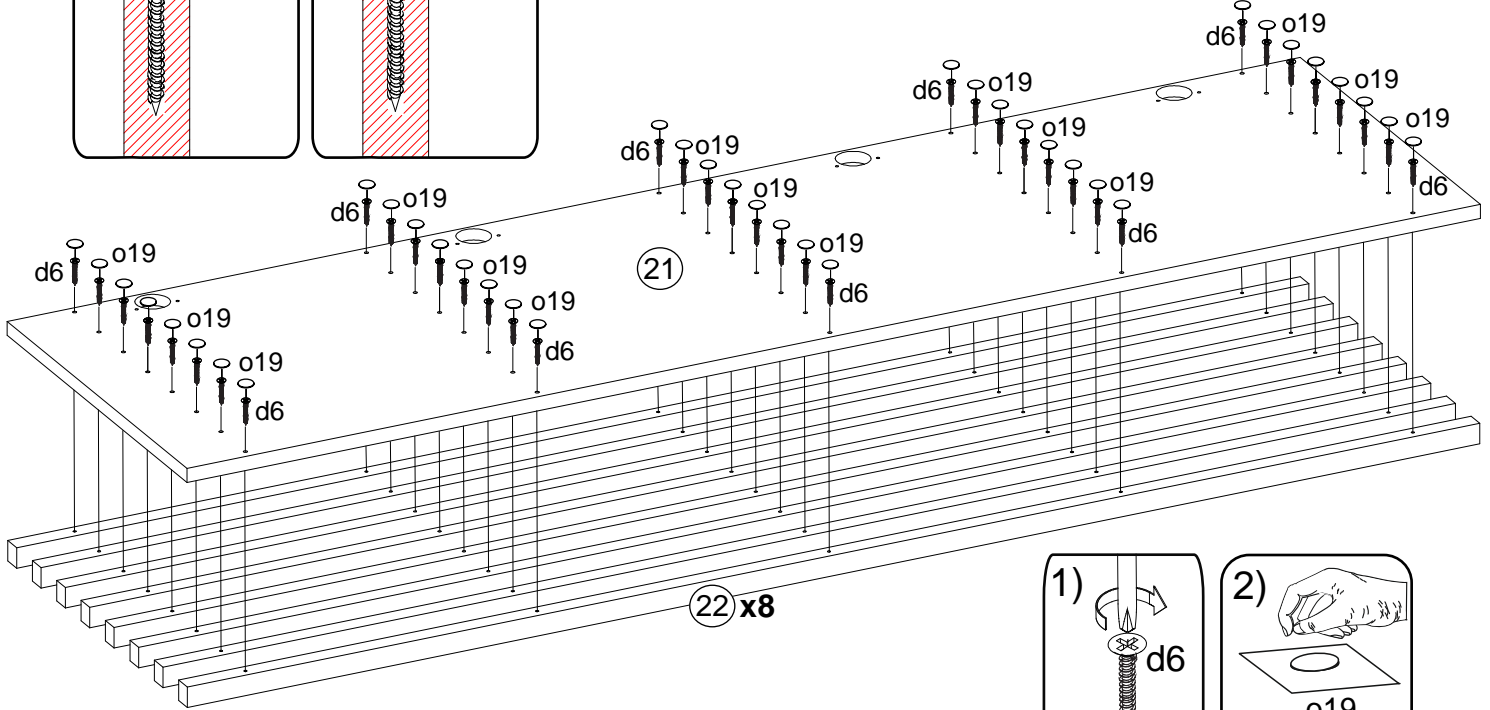
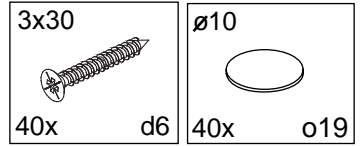
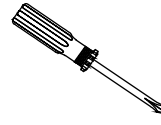
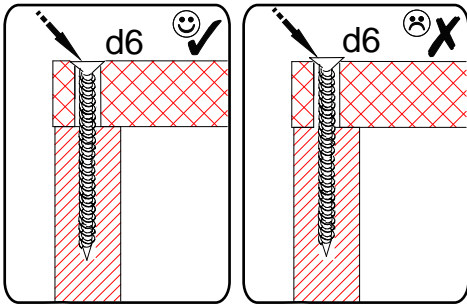

G

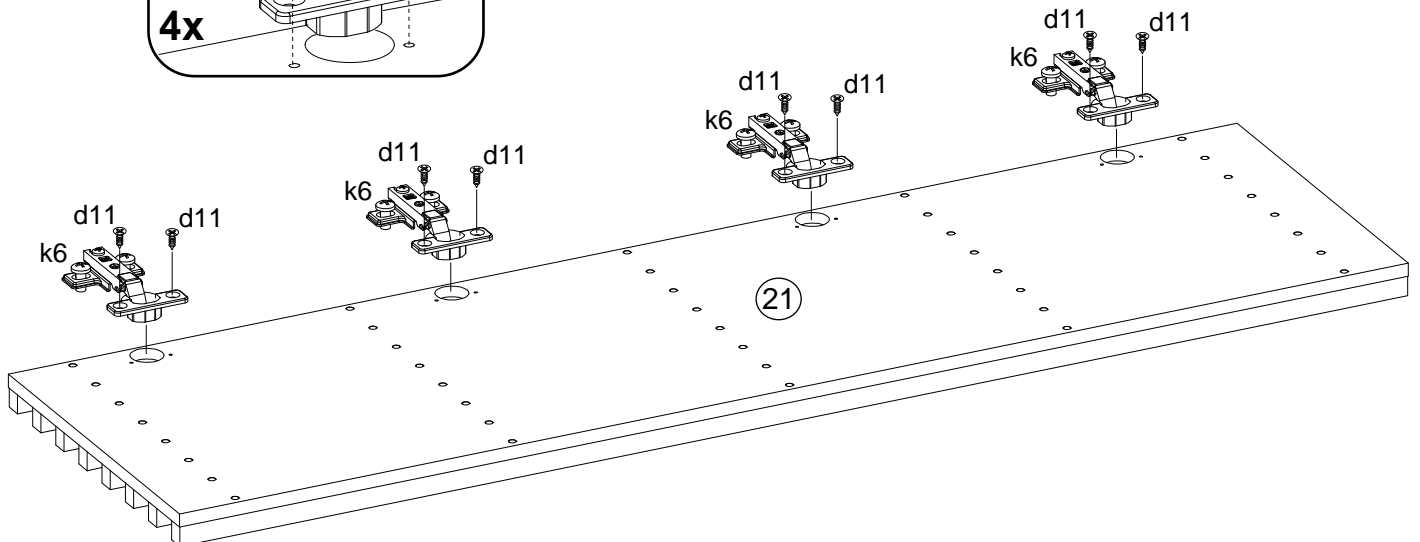
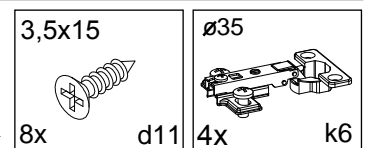
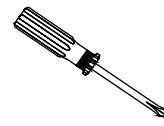
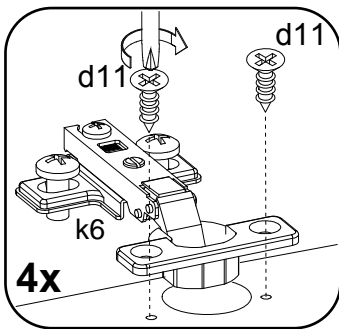

H

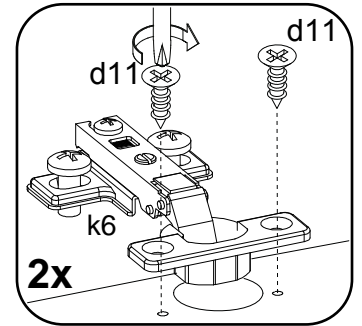
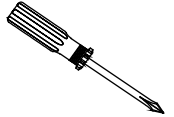
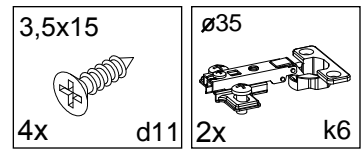
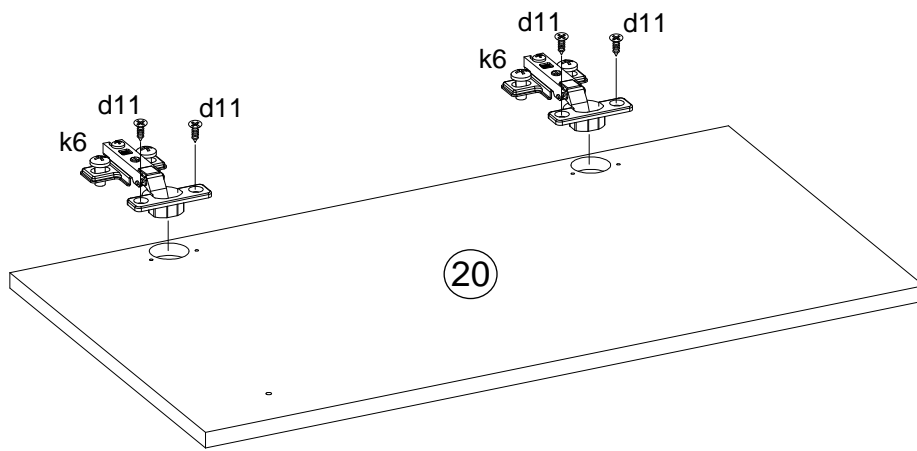

I

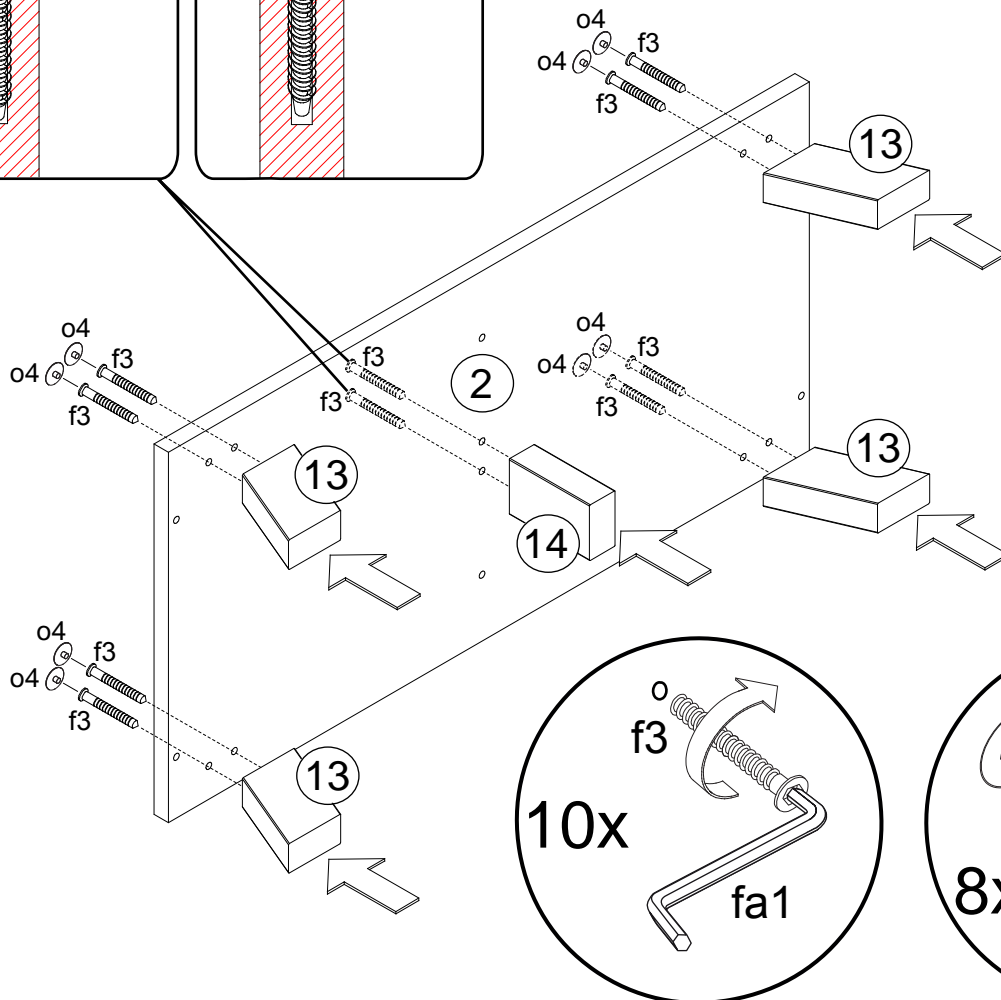
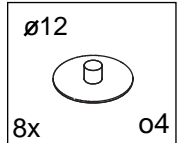
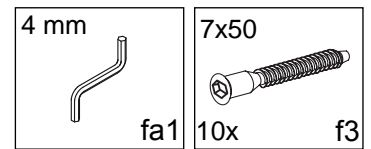
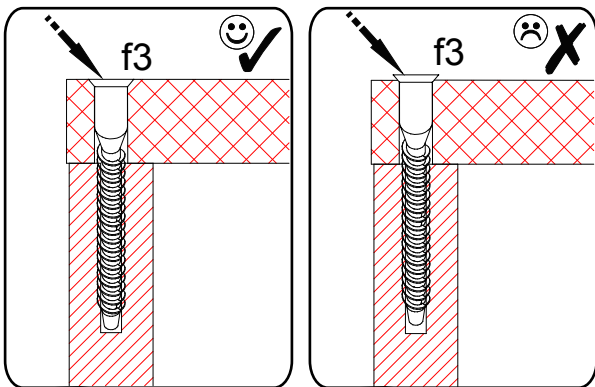

J

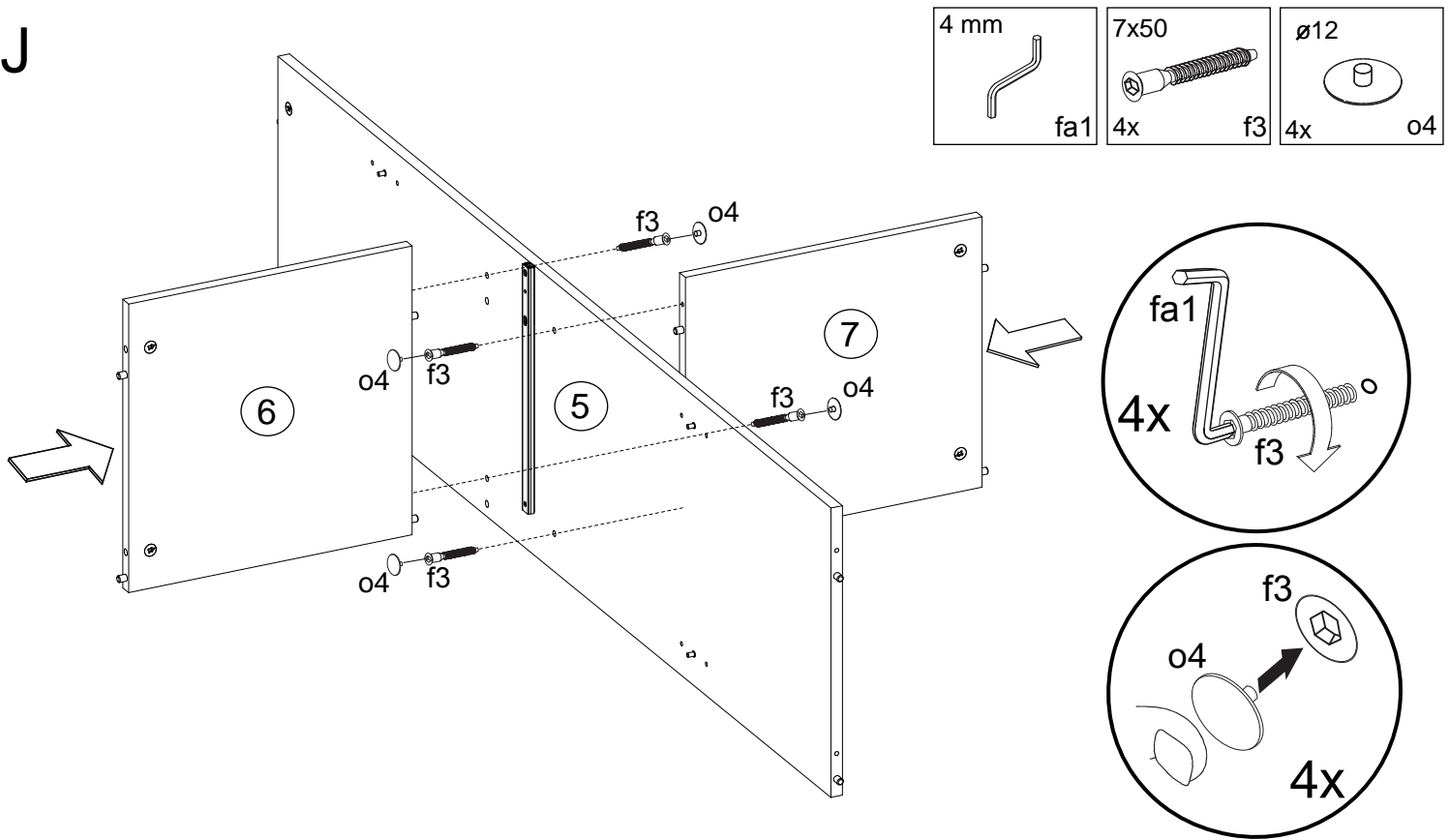

K

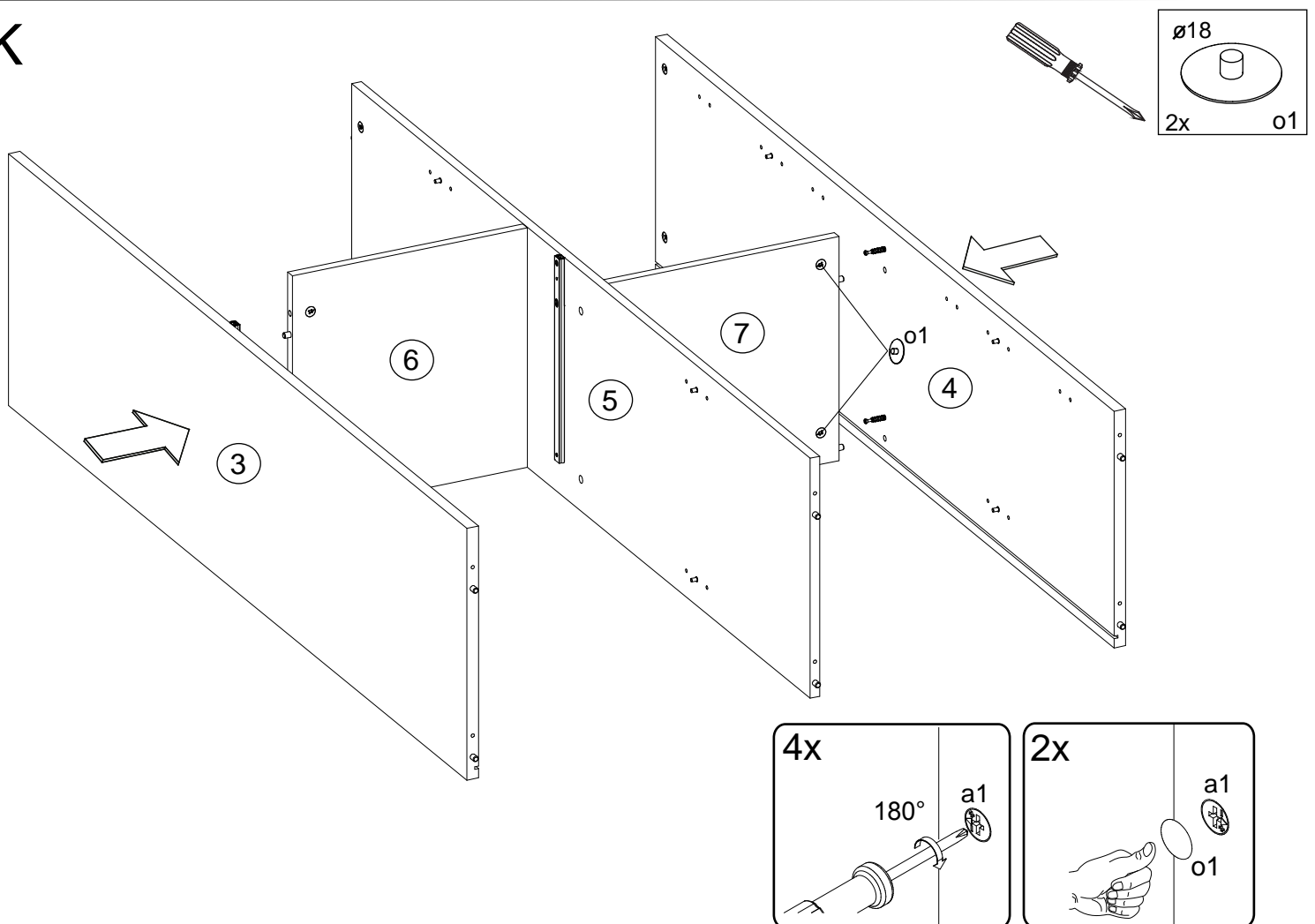

L

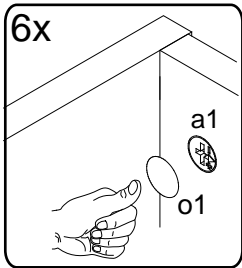
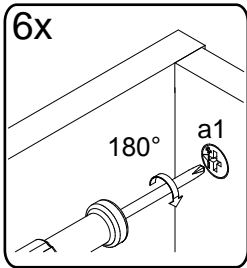
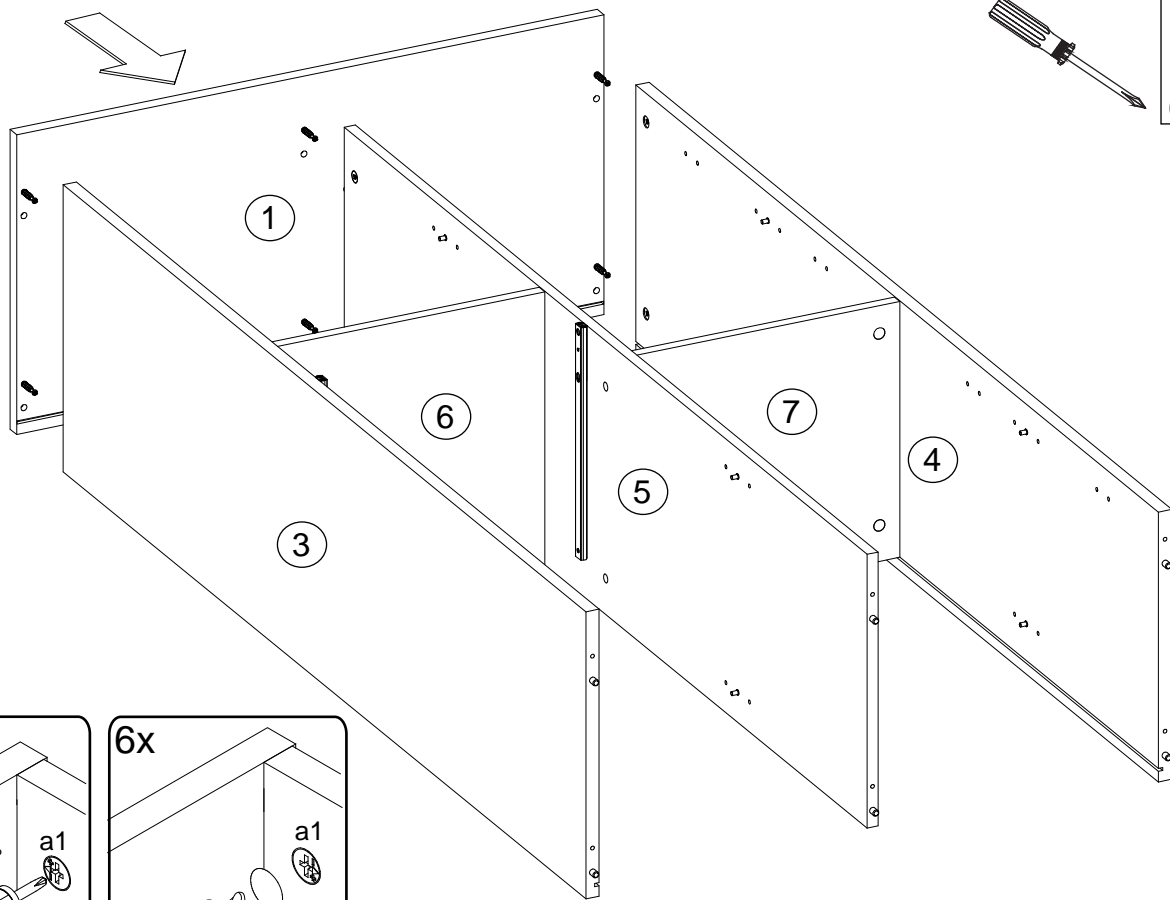

M

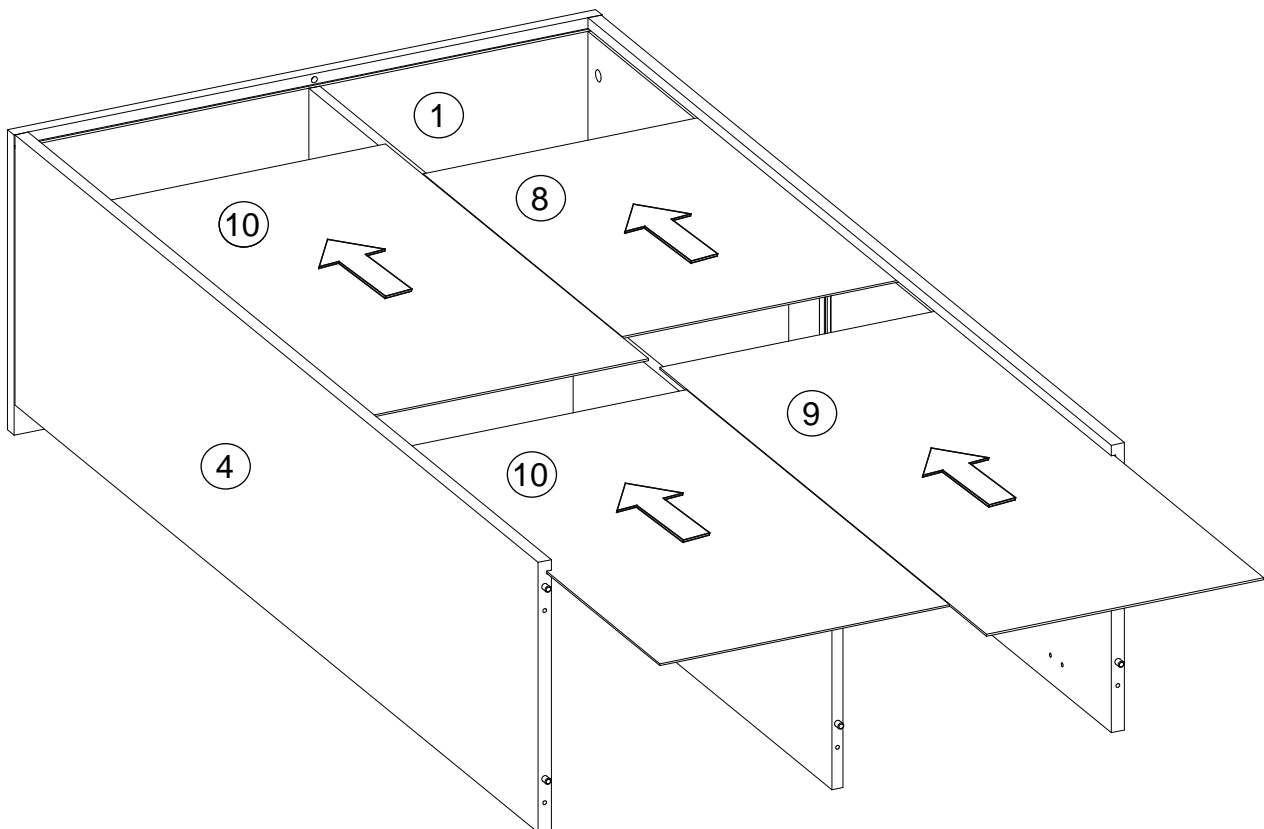

P

Le meuble doit être fixé au mur!
 Das Möbel muss an der Wand befestigt werden!
 This unit must be secured to a wall
 using suitable fixing (not supplied)

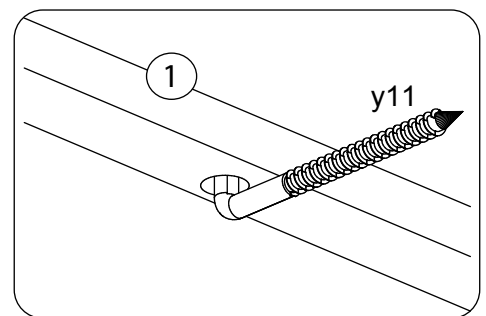
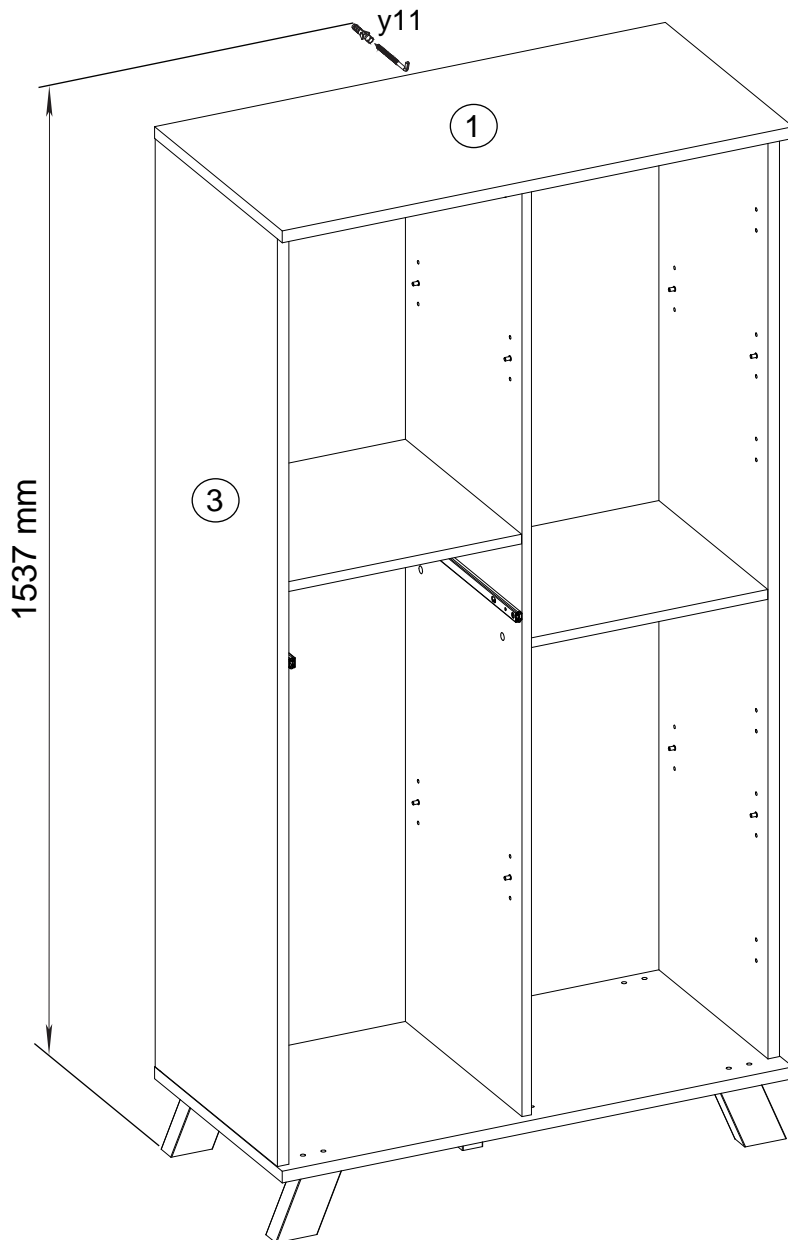
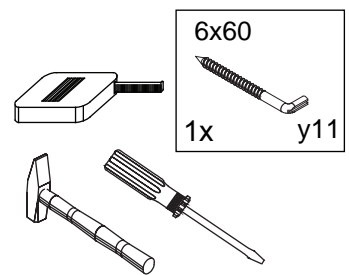

***Attention!**

Veillez-vous informer sur le type de cheville et vis approprié à la nature de votre mur.

***Achtung!**

Informieren Sie sich vor der Wandmontage über das geeignete Montagematerial für Ihre Wand!

***Caution!**

Please inform yourself about mounting material suitable for your wall before mounting.

Q

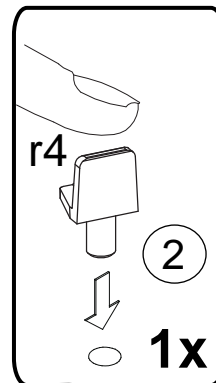
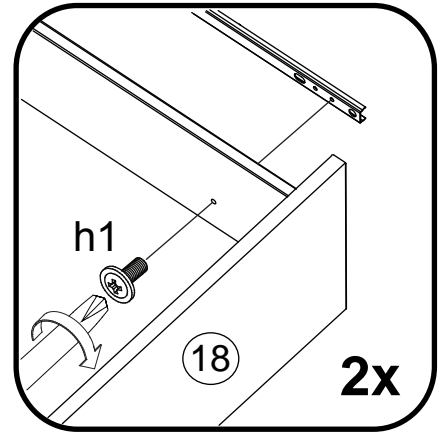
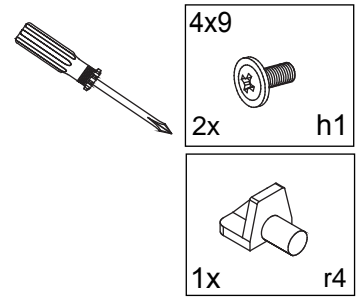
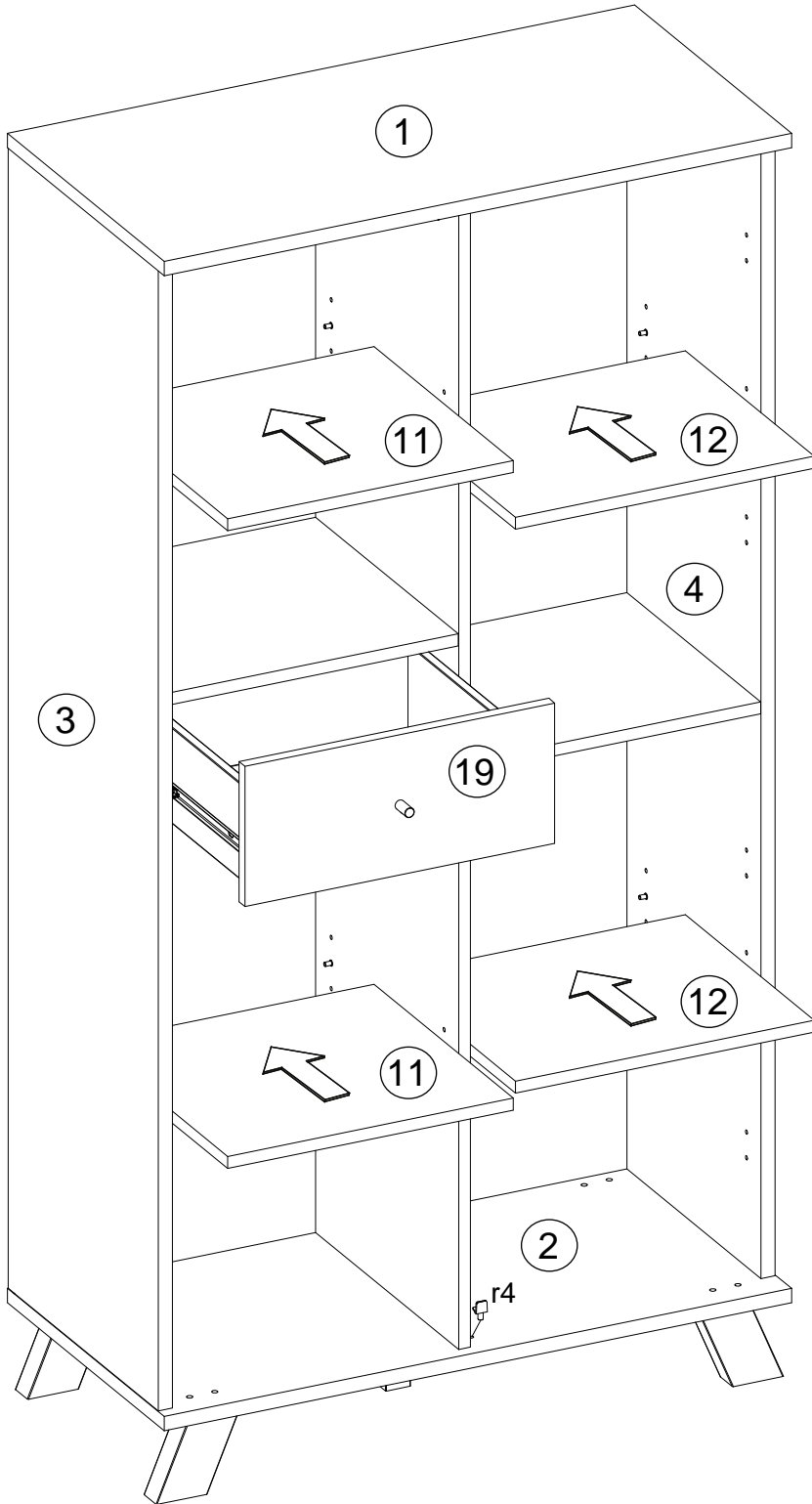

R

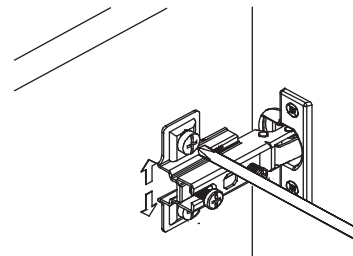
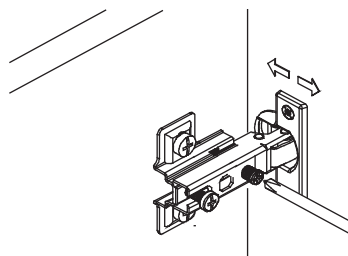
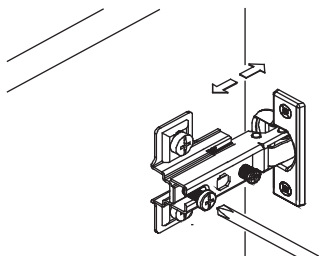
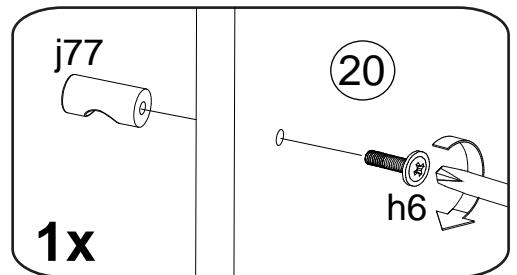
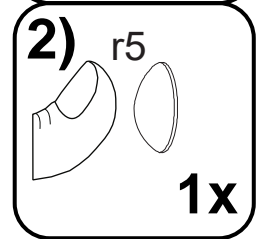
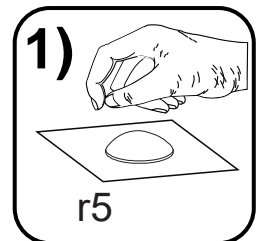
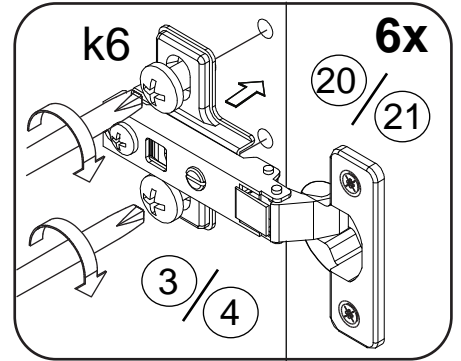
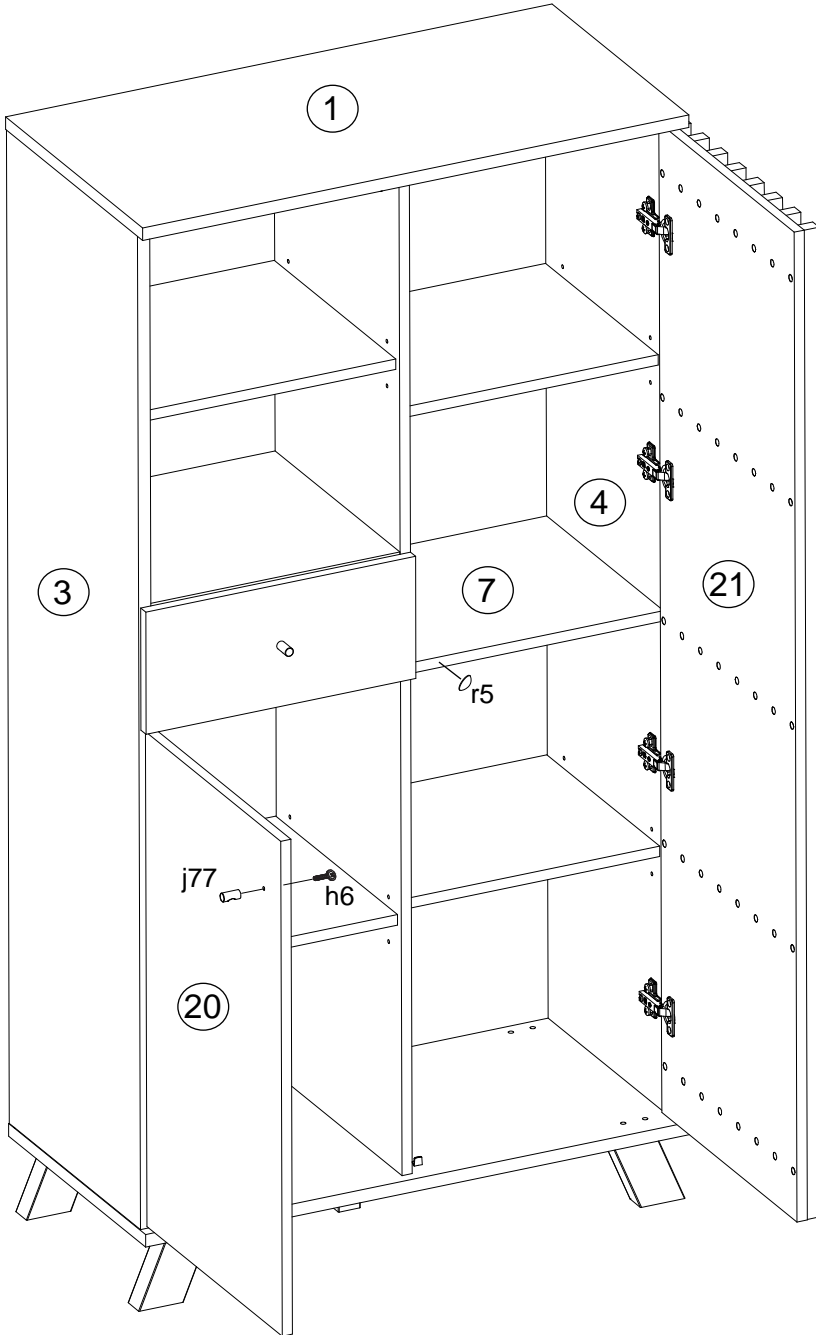
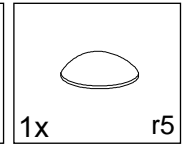
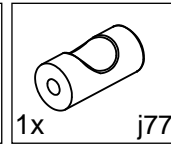
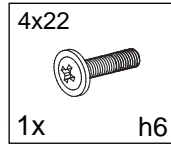
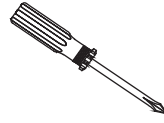



- Ⓓ Das Möbel muss an der Wand befestigt werden!
- Ⓔ Please ensure to mount the furniture to the wall!
- Ⓕ Les meubles doivent être fixés au mur!
- Ⓝ Het meubel moet aan de wand worden vastgemaakt!
- Ⓔ El mueble se tiene que fijar a la pared!
- Ⓡ Mebel należy przymocować do ściany!



- Ⓓ Informieren Sie sich vor der Wandmontage über das geeignete Montagematerial!
- Ⓔ Please get informed on suitable assembly materials before commencing the wall-mounting!
- Ⓕ Renseignez-vous sur le matériel de montage approprié avant le montage mural!
- Ⓝ Informeer u voor de wandmontage over het geschikte montagematerieel!
- Ⓔ Infórmese antes del montaje en la pared del material apropiado de montaje!
- Ⓡ Przed montażem na ścianie upewnij się, jaki jest potrzebny właściwy materiał montażowy!



- Ⓓ Beschaffen Sie sich das angemessene Material zur Wandbefestigung!
- Ⓔ Please obtain suitable wall-mounting materials!
- Ⓕ Procurez-vous le matériel approprié pour le montage mural!
- Ⓝ Verschaf u het adequate materieel voor de wandbevestiging!
- Ⓔ Procúrese el material adecuado para la fijación a la pared!
- Ⓡ Zakup odpowiedni materiał do przymocowania na ścianie!



- Ⓓ Lassen Sie die Wandbefestigung von einer fachkundigen Person vornehmen!
- Ⓔ Ensure all wall-mounting is carried out by competent personnel!
- Ⓕ Faites effectuer le montage mural par une personne compétente!
- Ⓝ Laat de wandbevestiging door een professional uitvoeren!
- Ⓔ Deje que la fijación a la pared la haga un profesional!
- Ⓡ Zlec przymocowanie do ściany odpowiednio doświadczonej osobie!

- Ⓡ Мебель должна крепиться к стене!
- Ⓓ Il mobile deve essere fissato alla parete!
- Ⓡ A bútor a falon rögzítendő!
- Ⓓ O móvel tem que ser fixado na parede!
- Ⓔ Nábytek musí být připevněn ke stěně!

- Ⓡ Перед тем, как крепить мебель к стене, получите информацию о подходящем крепежном материале!
- Ⓓ Prima del fissaggio alla parete, informarsi sul materiale di montaggio adatto!
- Ⓡ A falra szerelés előtt tájékozódjon, hogy ehhez milyen szerelőanyagok szükségesek!
- Ⓓ Antes da montagem na parede, informe-se sobre o material de montagem adequado!
- Ⓔ Informujte se o vhodném montážním materiálu před montáží na stěnu!

- Ⓡ Приобретите соответствующий материал для крепления к стене!
- Ⓓ Procurarsi il materiale opportuno per il fissaggio alla parete!
- Ⓡ Szerezze be a falra szereléshez szükséges, megfelelő anyagokat!
- Ⓓ Obtenha o material adequado para a montagem na parede!
- Ⓔ Opatřte si vhodný materiál pro montáž na stěnu!

- Ⓡ Поручите выполнение работ по креплению к стене специалисту!
- Ⓓ Far effettuare il fissaggio alla parete ad un esperto!
- Ⓡ A bútor falra rögzítését végeztesse ehhez értő személlyel!
- Ⓓ A montagem na parede deve ser executada por uma pessoa competente!
- Ⓔ Montáž na stěnu nechte provést odborně způsobilou osobou!

