

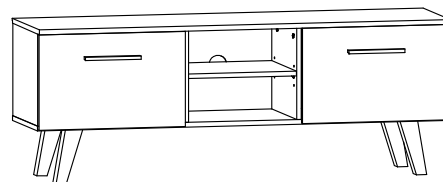













RTV NORD 140

L-140 H-52 D-39



x4  AKC00019	x16  AKC00120	x16  AKC00004	x8  AKC00029	x8  AKC00151	x8  AKC00004
x4  AKC00023	x4  ZAW00013	x8  3.5x16 AKC00026	x40  AKC00018	x1  UCH00037 WHITE UCH00038 BLACK	x1  AKC00017
x4  NOG00039 WHITE NOG00038 BLACK					

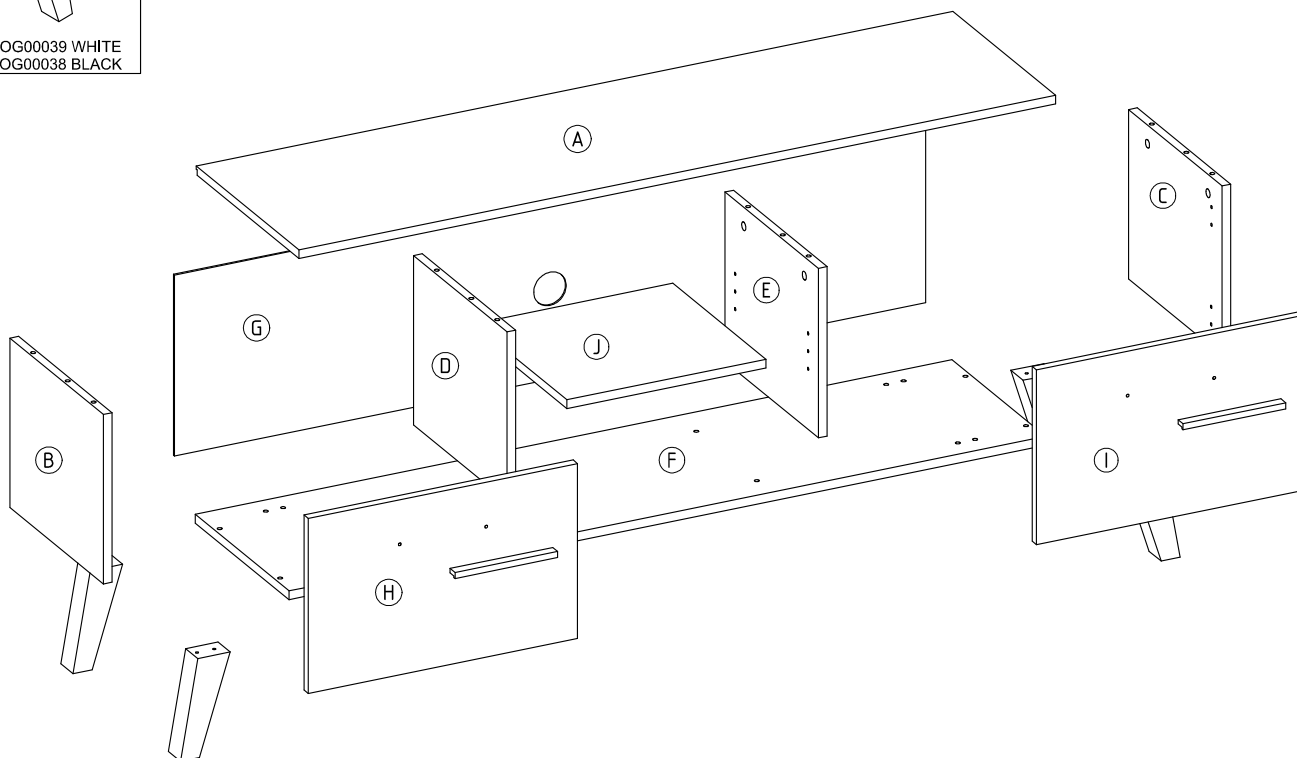
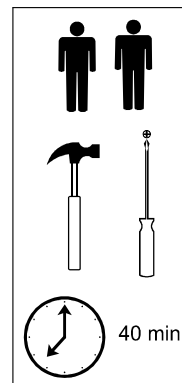

PL- Proszę nie montować mebla , jeśli jego elementy są uszkodzone.

Przed zmontowaniem poszczególne elementy mebla należy dokładnie obejrzeć. W przypadku uszkodzeń, należy je zgłosić wraz z dokumentacją zdjęciową , celem rozpatrzenia reklamacji i podjęcia właściwych działań.

EN- Please do not assemble the furniture if its parts are damaged.

Before assembling, individual elements of the furniture should be carefully inspected. In case of visible damage, it should be reported along with photographic documentation , to analyse the complaint and take appropriate action.

FR- Si vous constatez que les pièces sont endommagées, veuillez ne pas monter le meuble.

Avant le montage, les éléments individuels du mobilier doivent être soigneusement inspectés. En cas d'un endommagement, ils doivent être signalés avec la documentation photographique afin d'examiner la réclamation et de prendre les mesures appropriées.

DE- Bitte montieren Sie die Möbel nicht, wenn ihre Teile beschädigt sind.

Vor dem Zusammenbau sollten einzelne Elemente der Möbel sorgfältig geprüft werden.Im Schadensfall sollten sie zusammen mit der Foto Dokumentation gemeldet werden, um die Beschwerde zu prüfen und geeignete Maßnahmen zu ergreifen.

FIN-Ennen asennusta tarkista , että kaikki tässä asennusohjeessa mainitut osat löytyvät paketista.

Mikäli paketissa olevissa osissa on lohkeamia tai naarmuja tai muuta huomautettavaa, kuvaa osa ja ota yhteyttä tuotteen myyneeseen liikkeeseen.

1

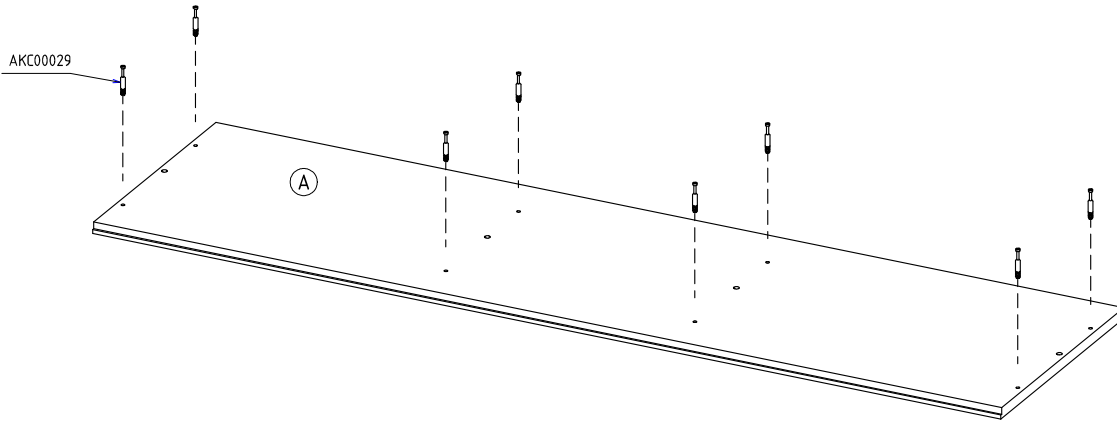

2

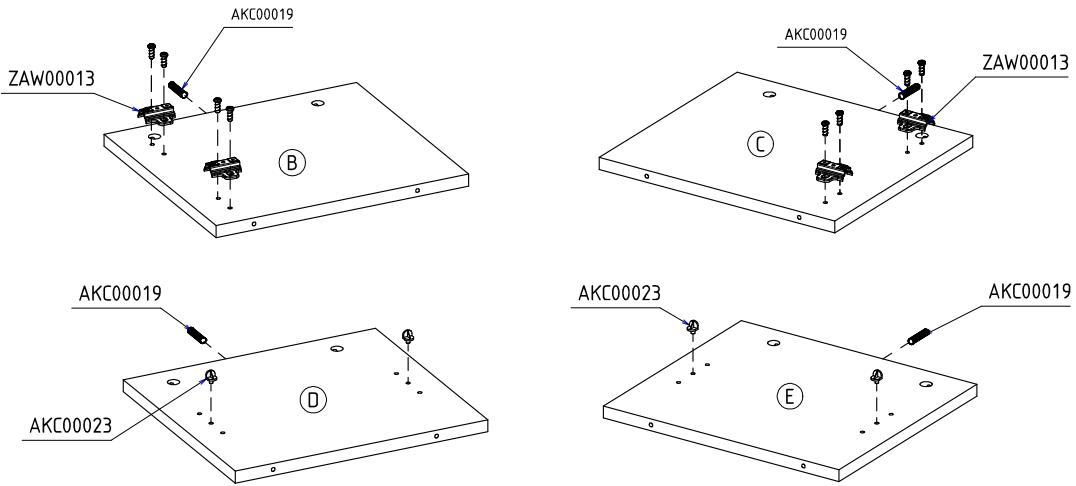

3

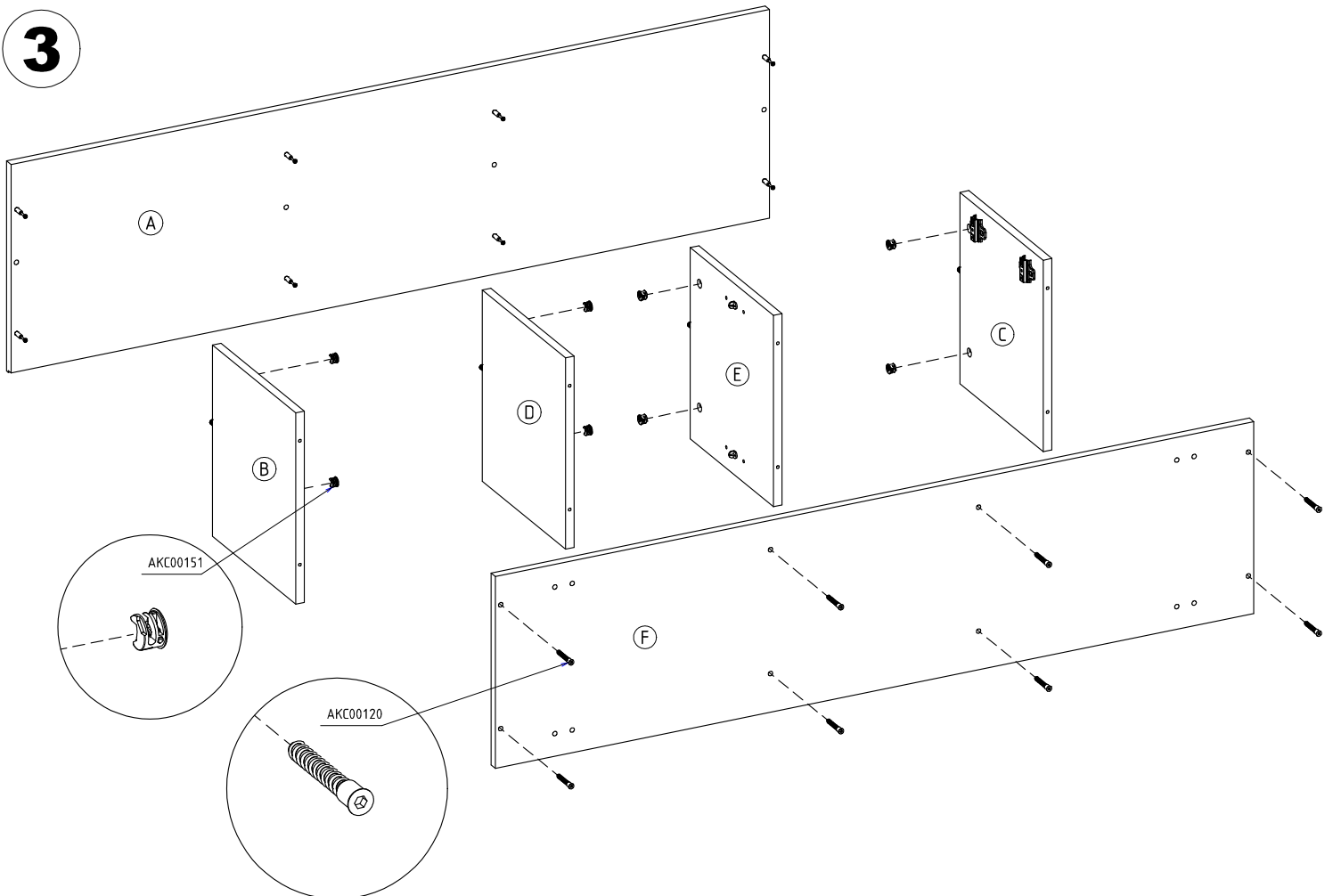

4

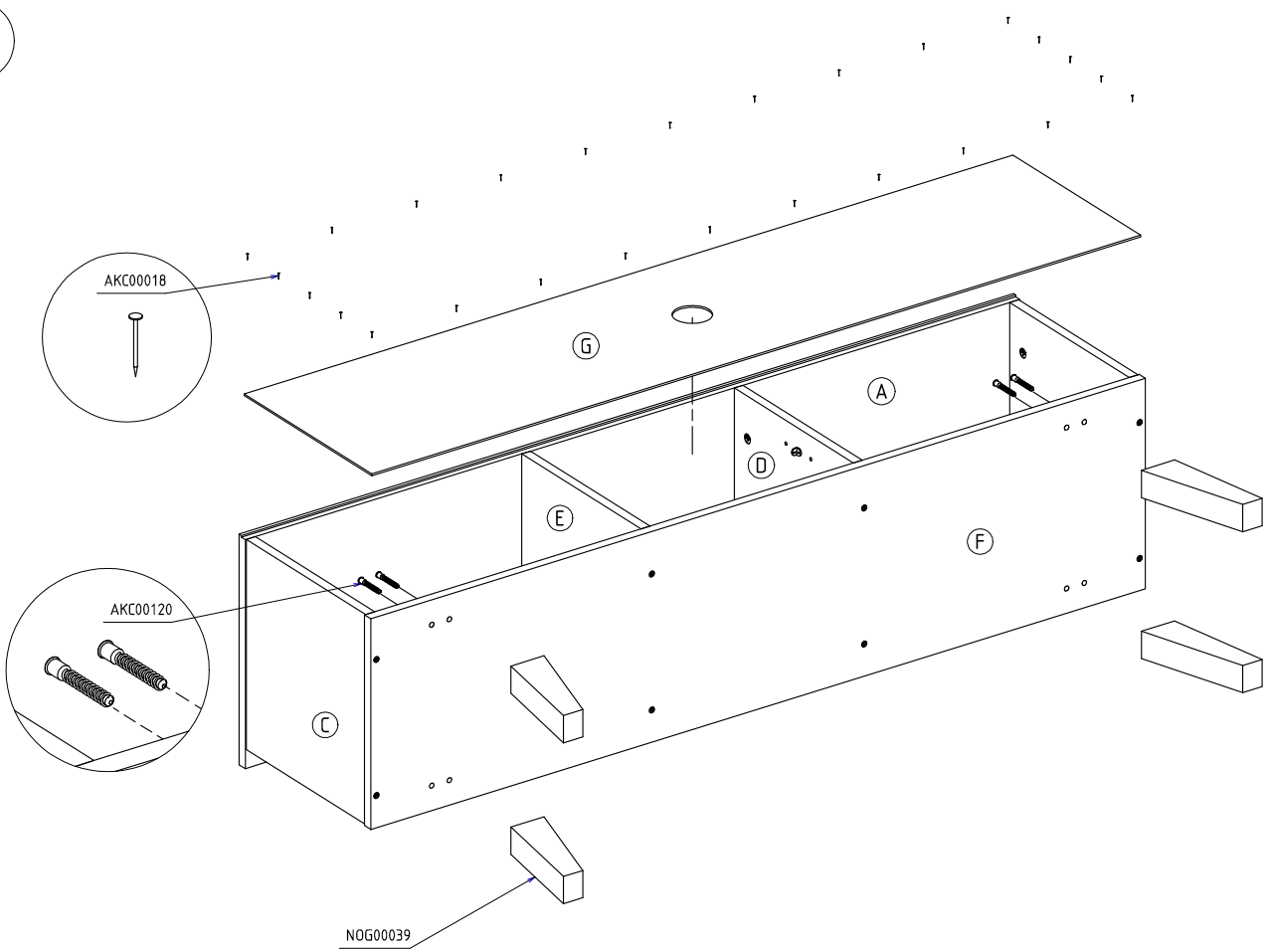

5

